

Evaluation Criteria:

Evaluation Criteria Sum Weightings

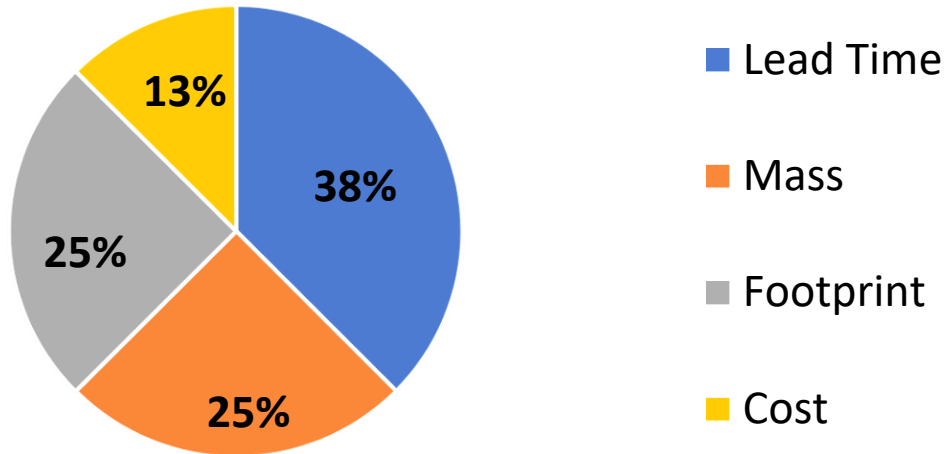

$$S = S_A(0.38S_{LT} + 0.25S_M + 0.25S_{FT} + 0.13S_C)$$

Satisfaction Curve Shapes:

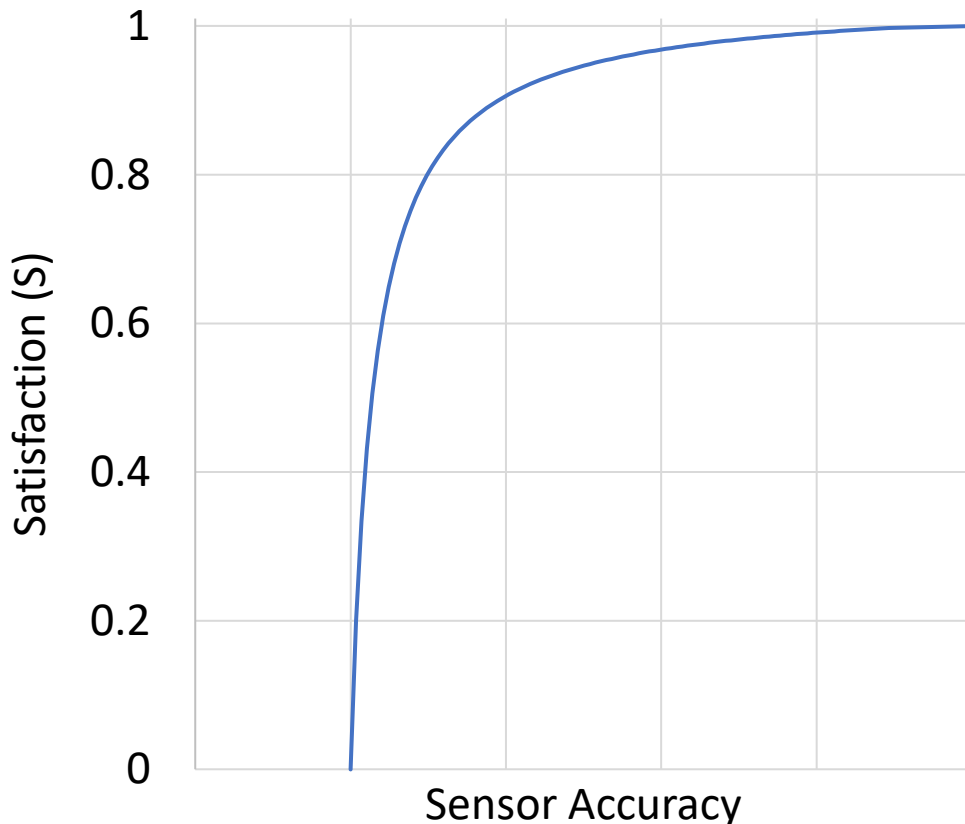

Satisfaction Curve Shapes:

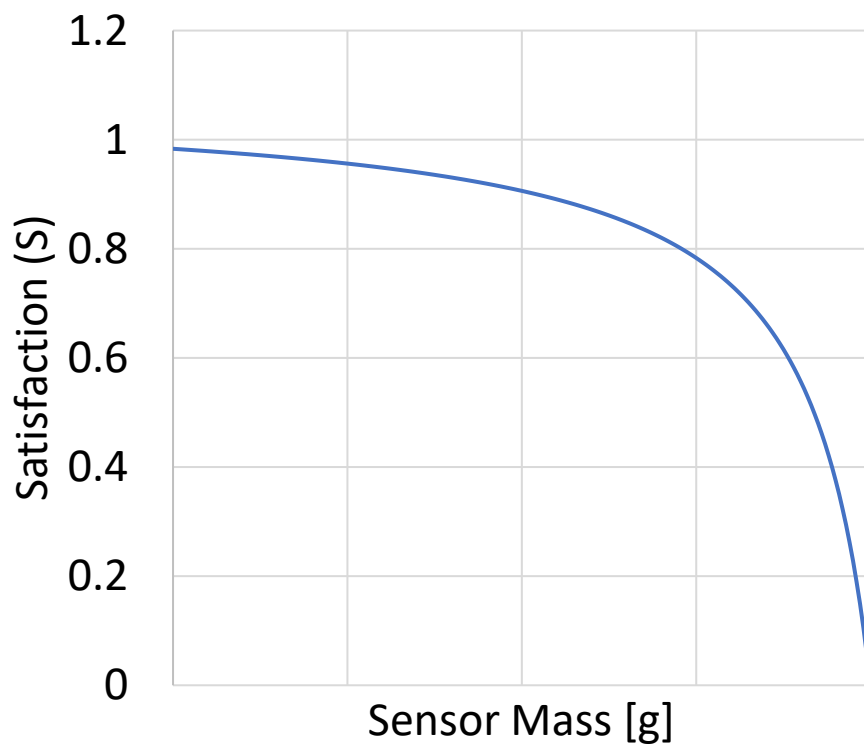
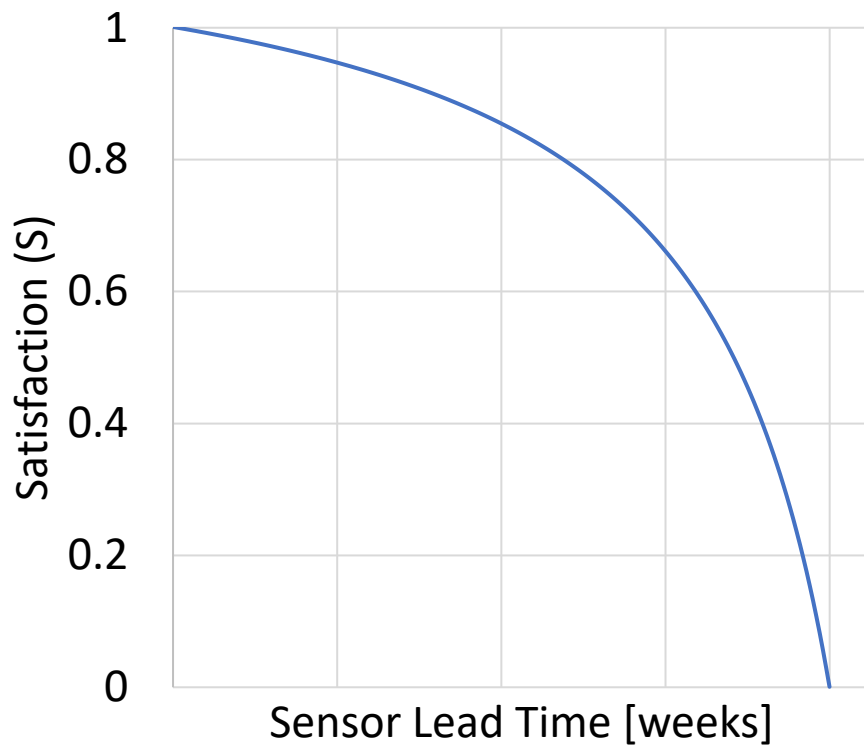

Satisfaction Curve Shapes:

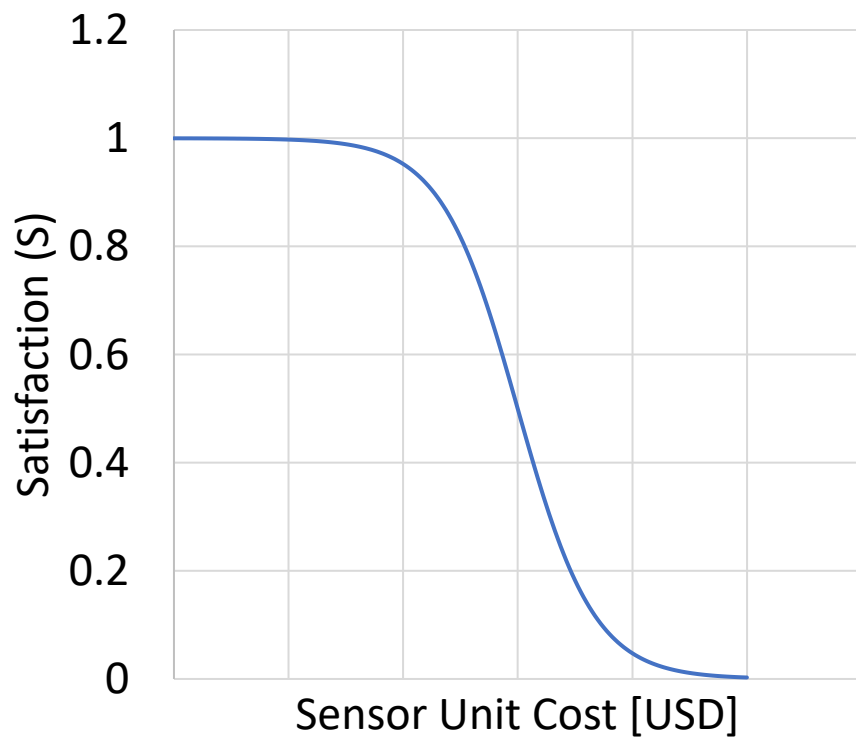
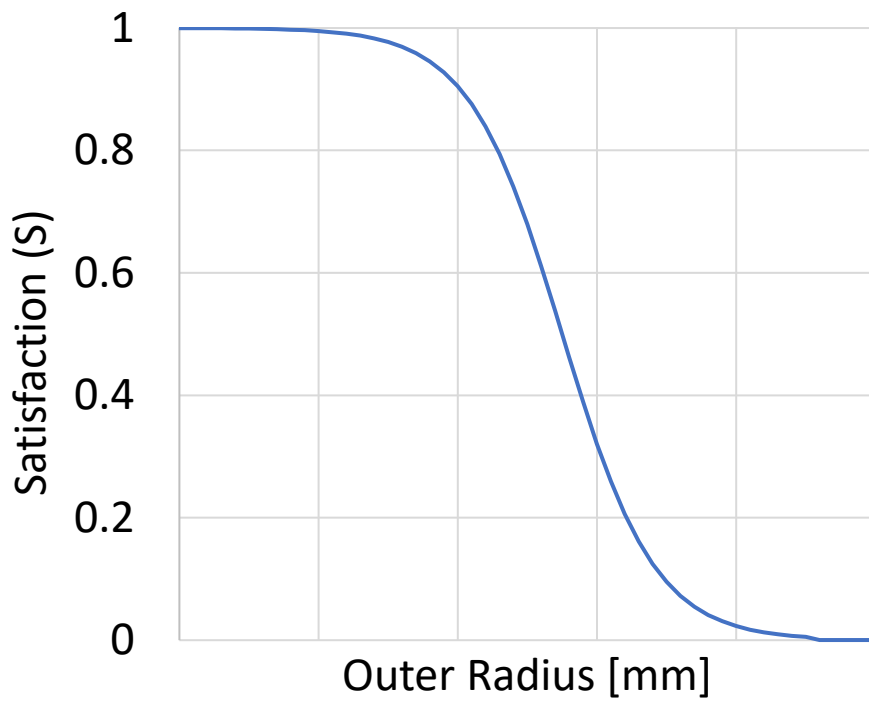

Sealing Prototypes:



Final Prototype:

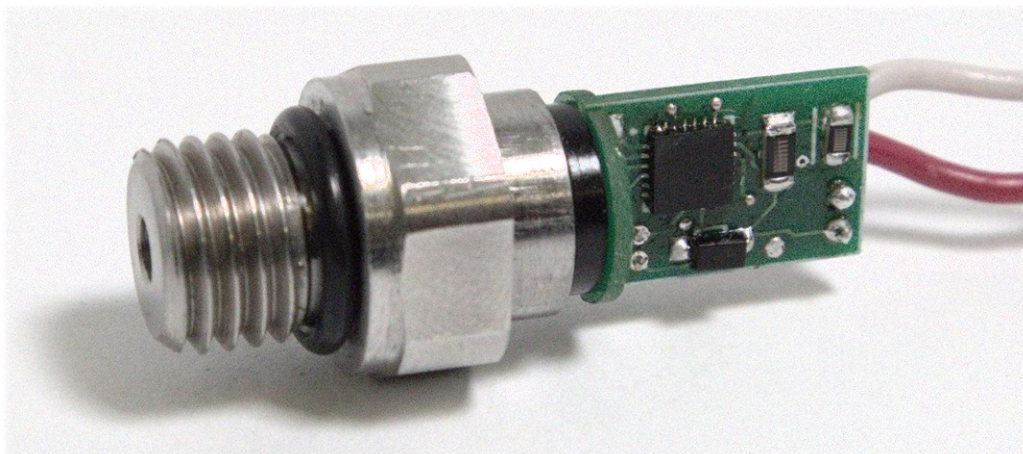
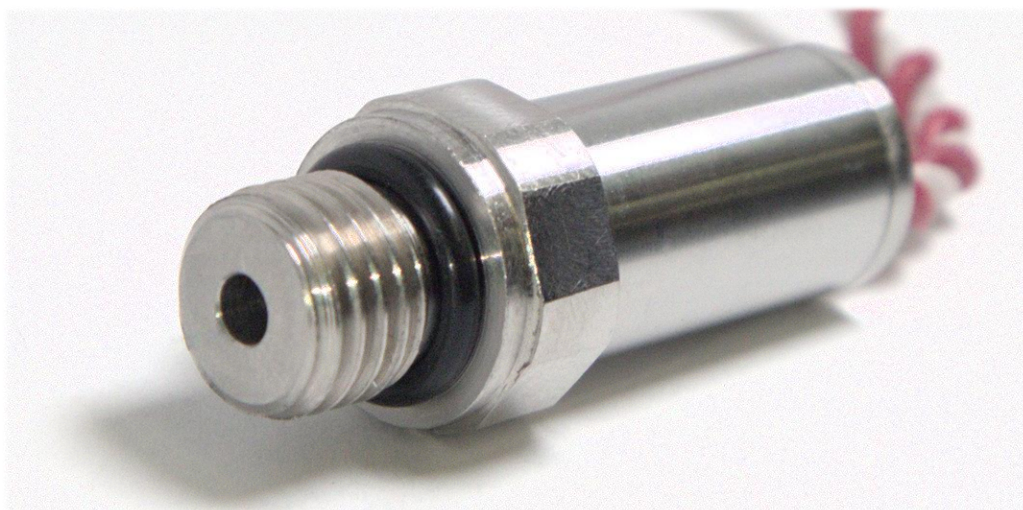

Final Prototype:

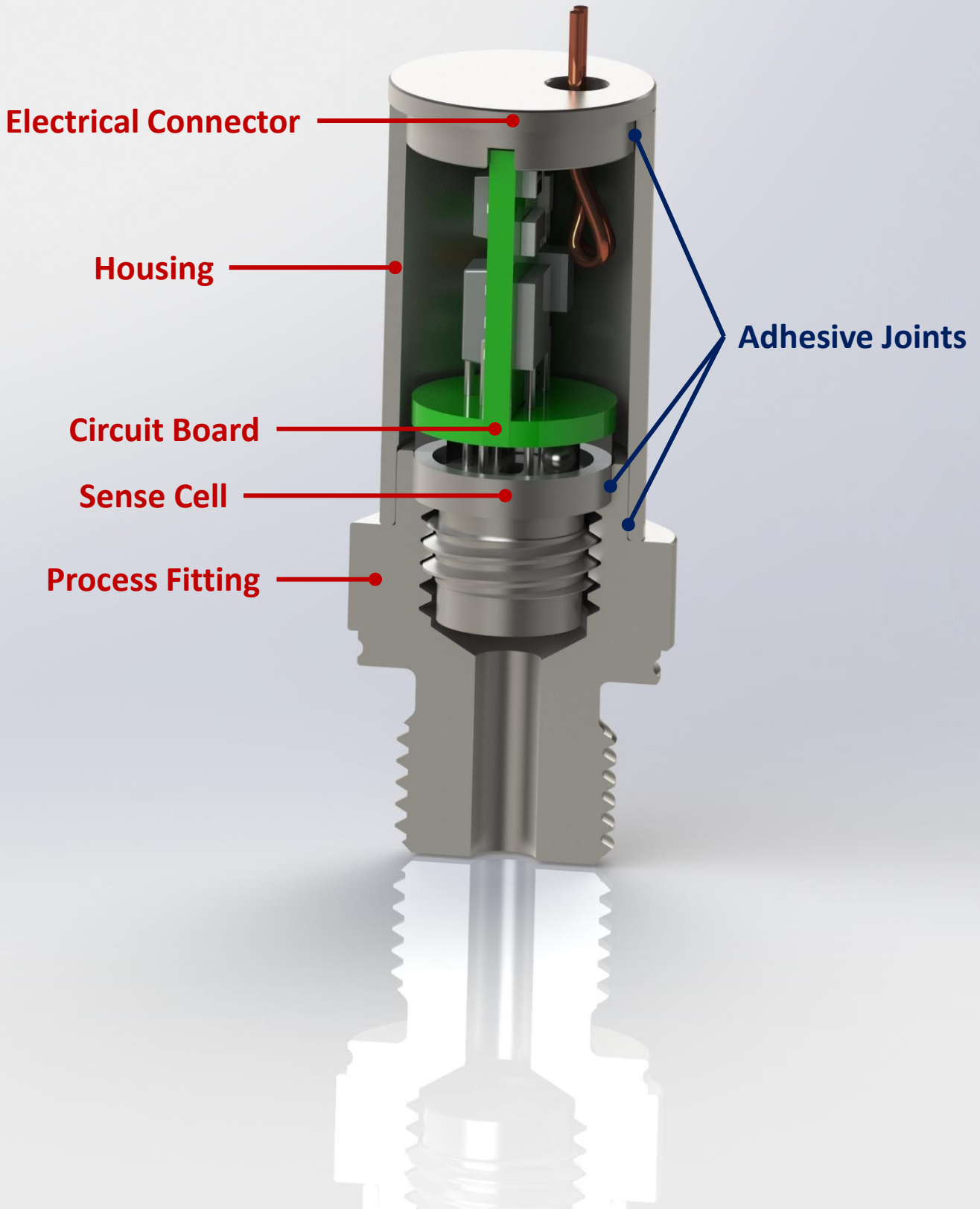

Radiation Background:

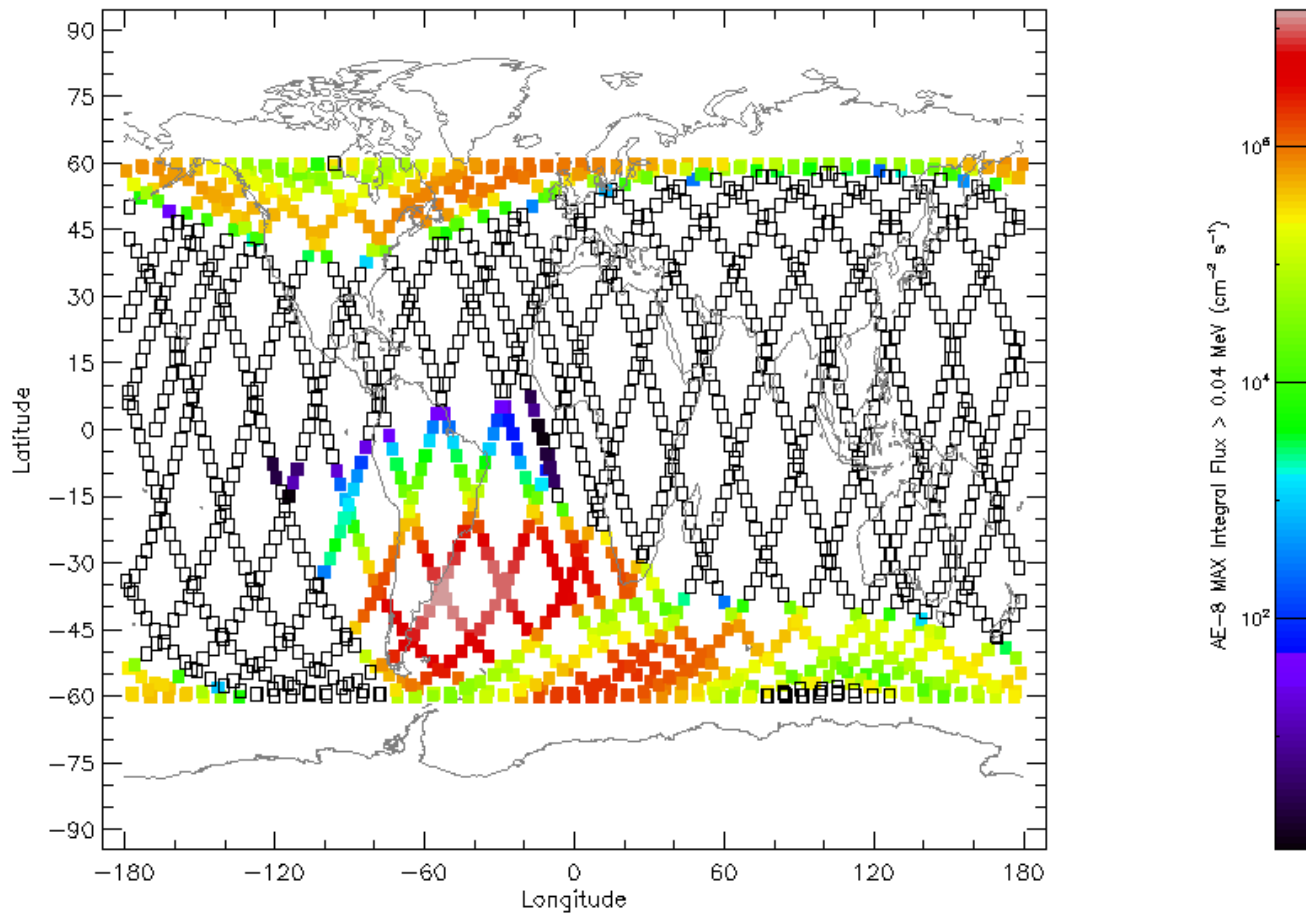
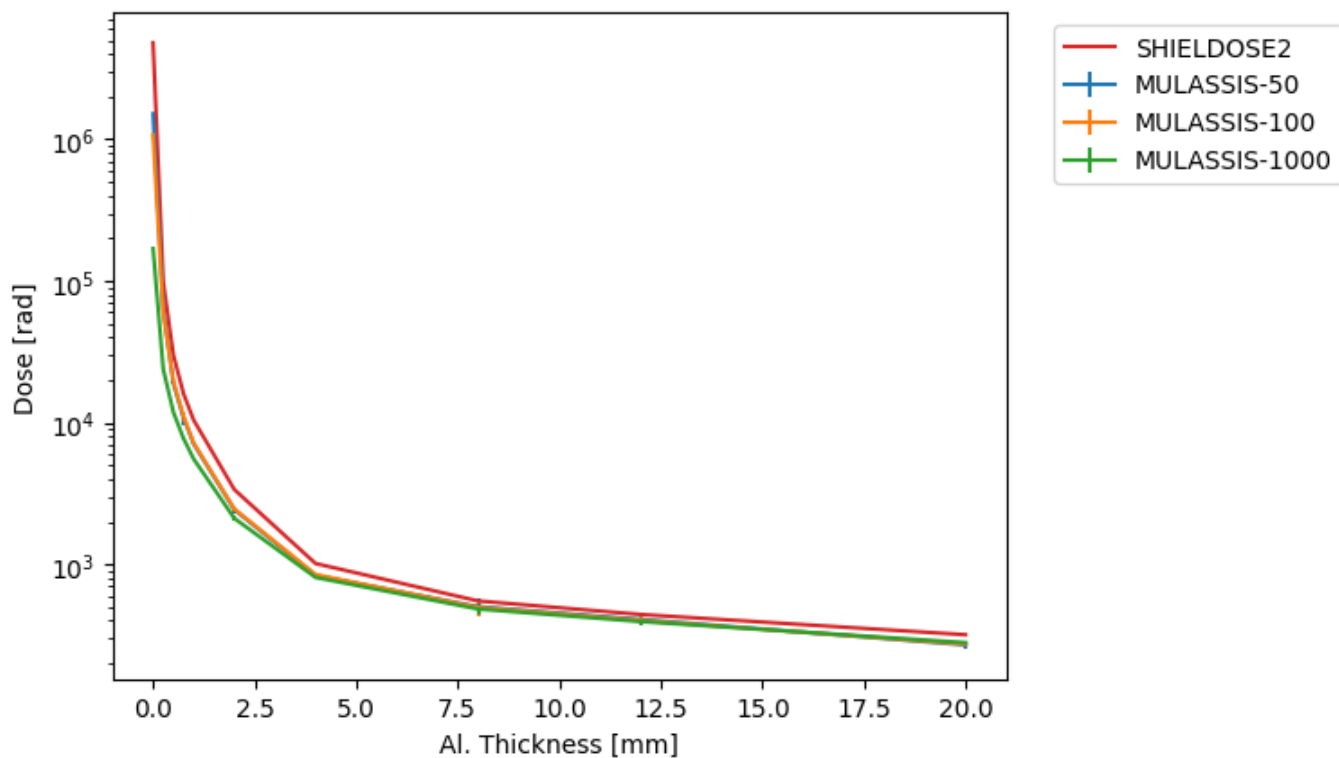

Radiation Background:

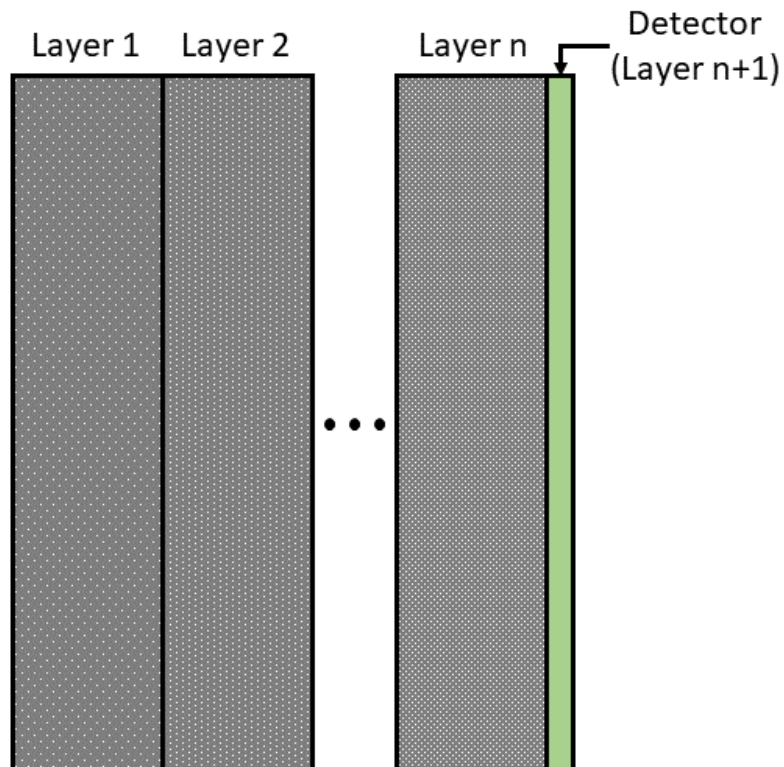
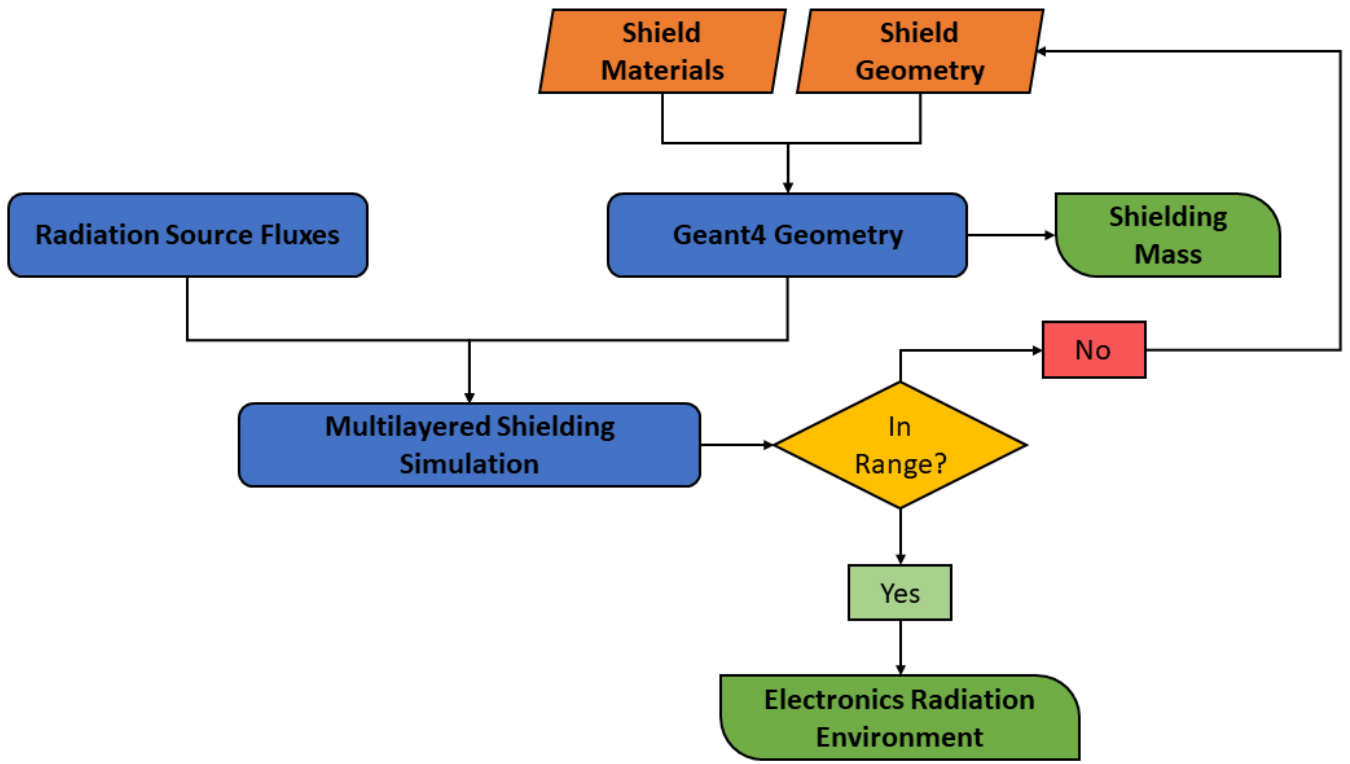

Vibration Background:

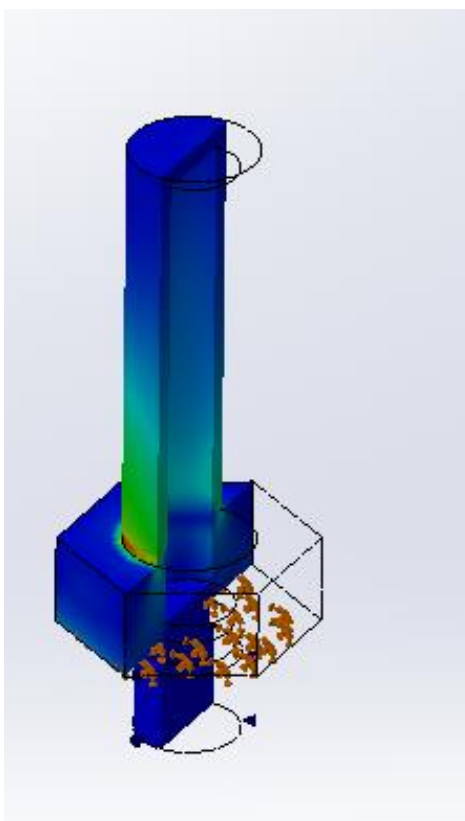
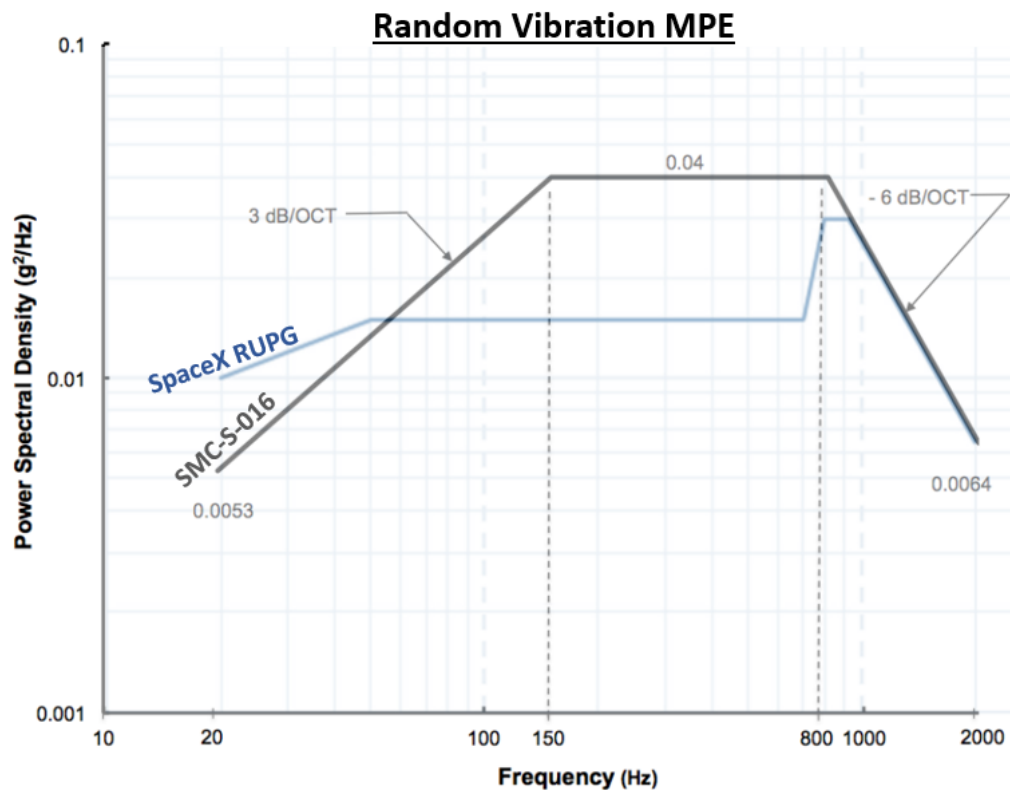

Test Bench:

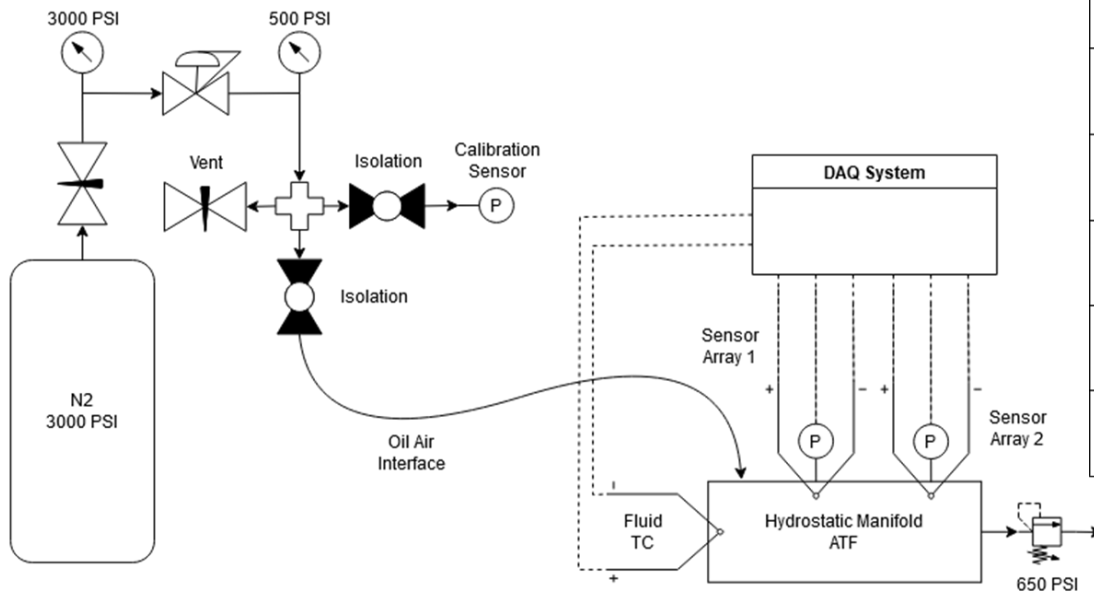

Legend	
	Needle Valve
	Downstream Regulator
	Manual Ball Valve
	Relief Valve
	Pressure Gauge
	Pressure Sensor
	Thermocouple

Manifold Designed per, CSA B51 and ASME B31.1

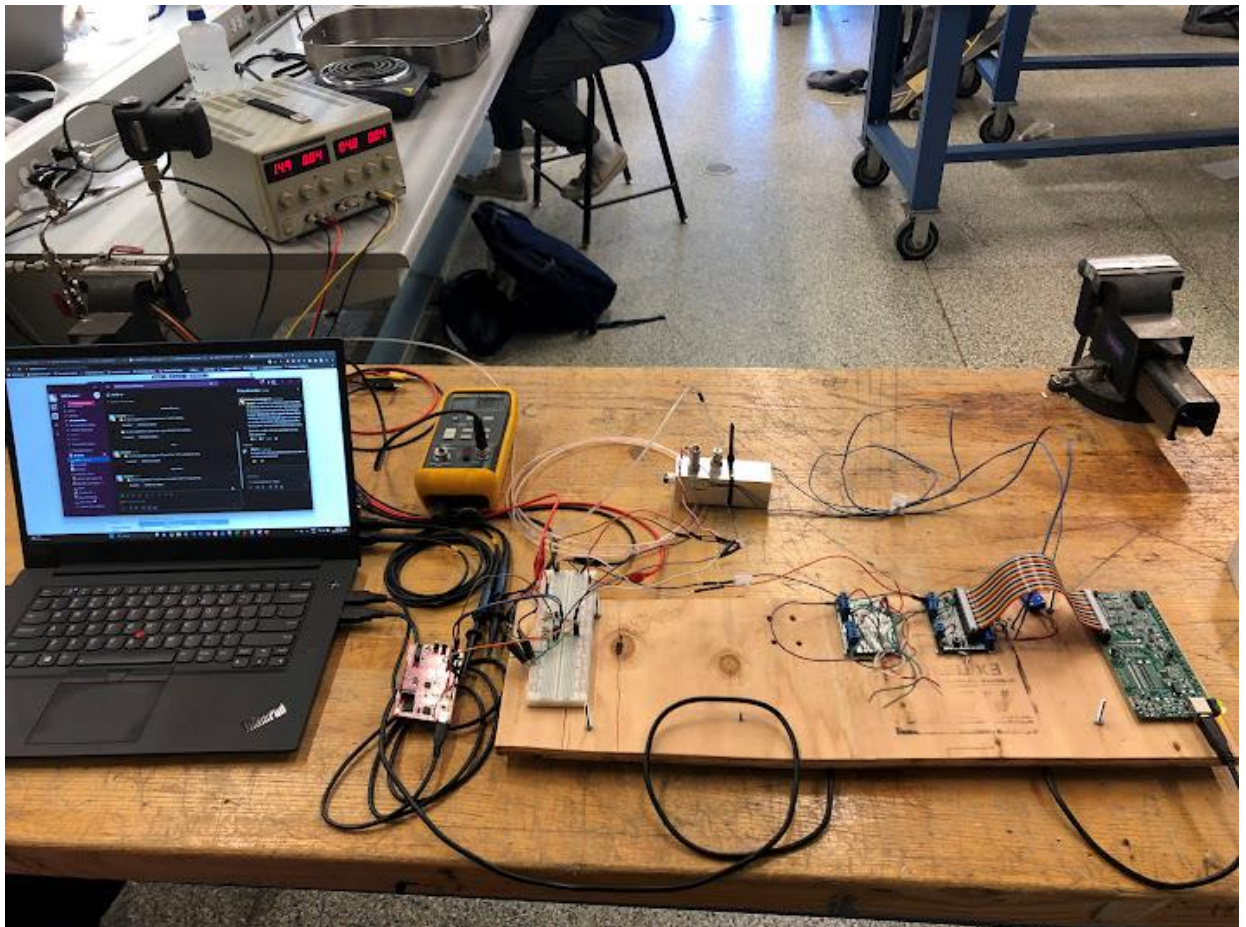

Electronic Circuit Architecture:

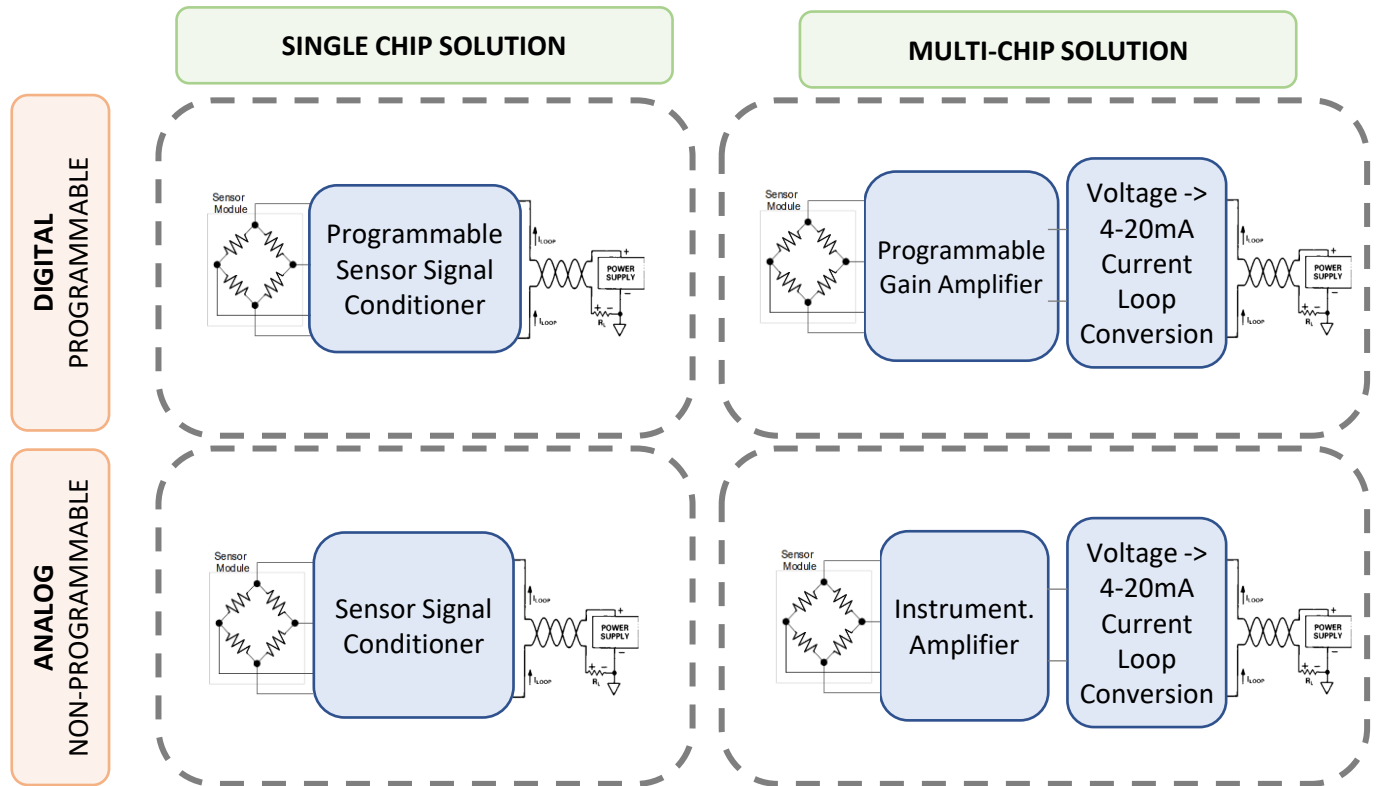

Analog Sensor with Current Loop Output, OWI, and External JFET

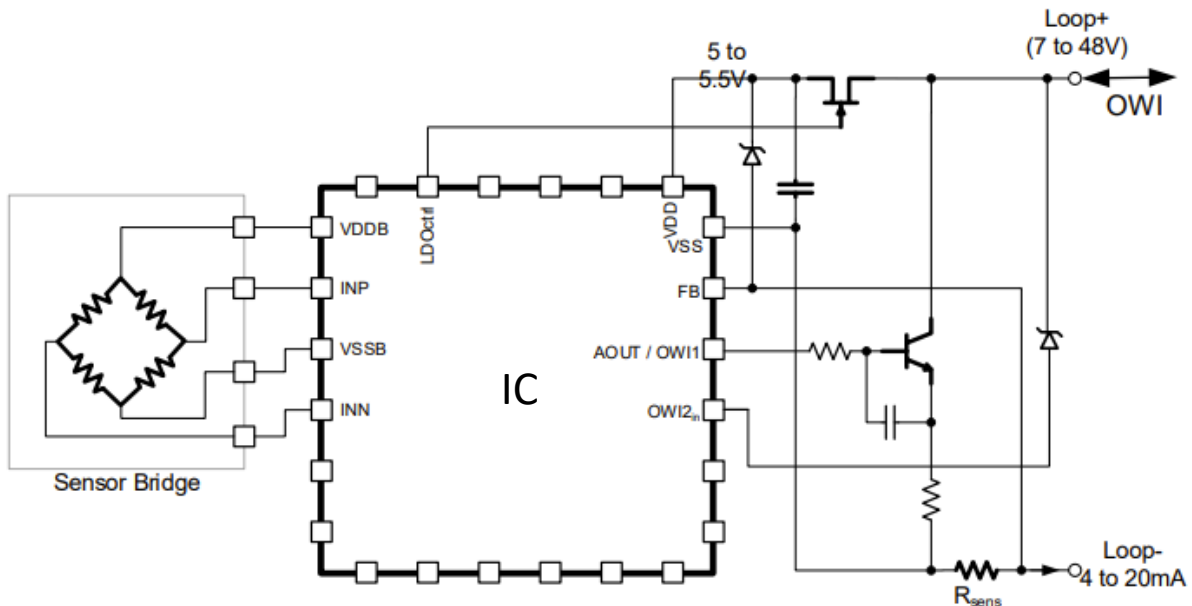

Circuit Evolution:

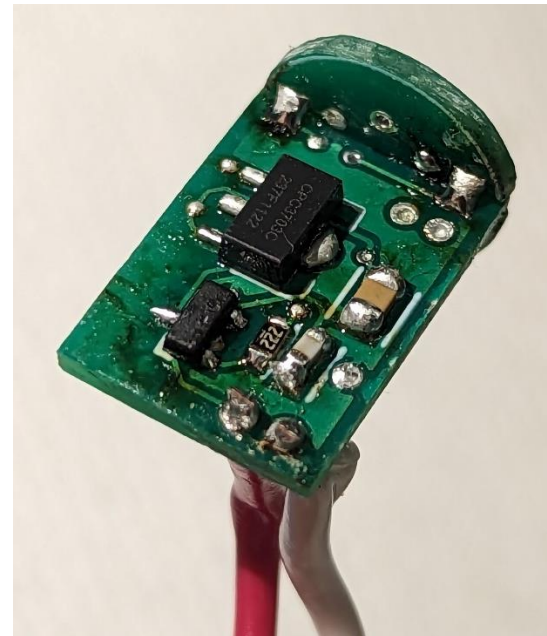
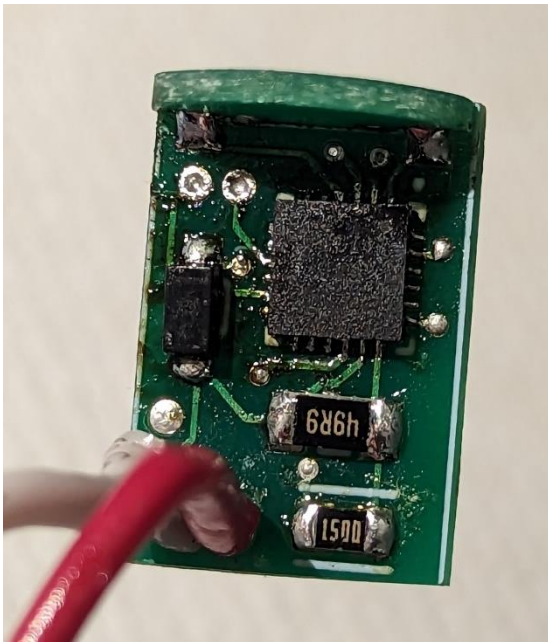
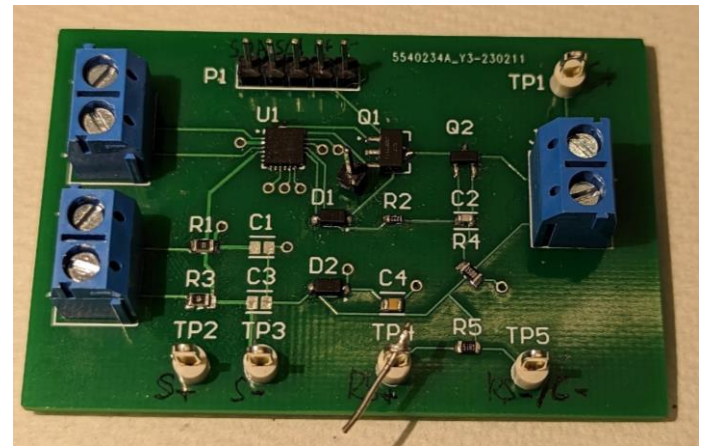
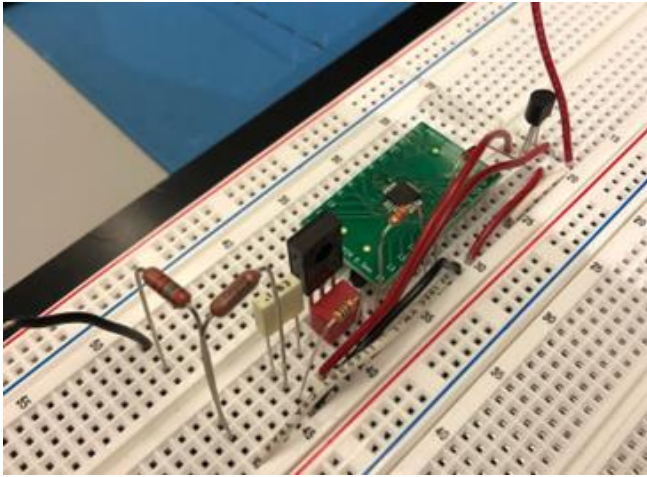
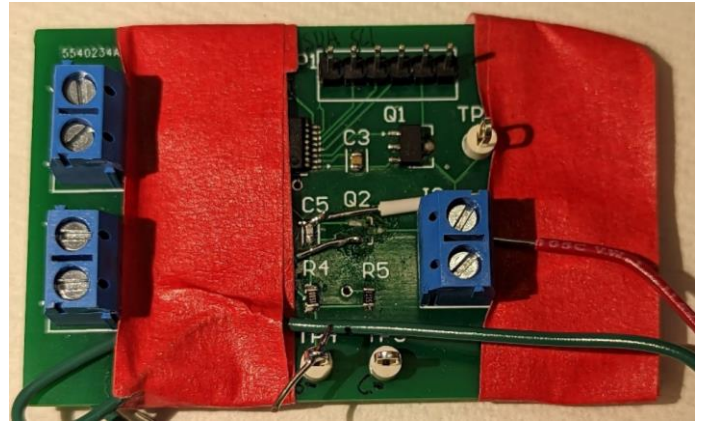
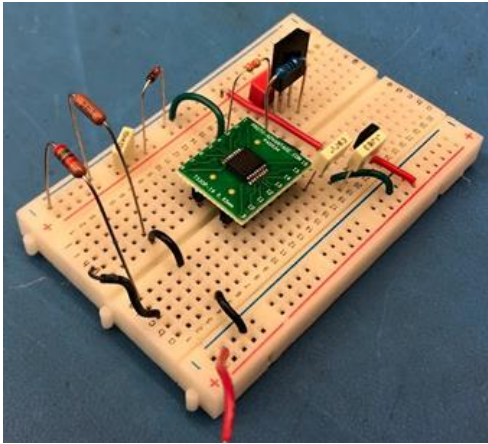

Circuit Layout:

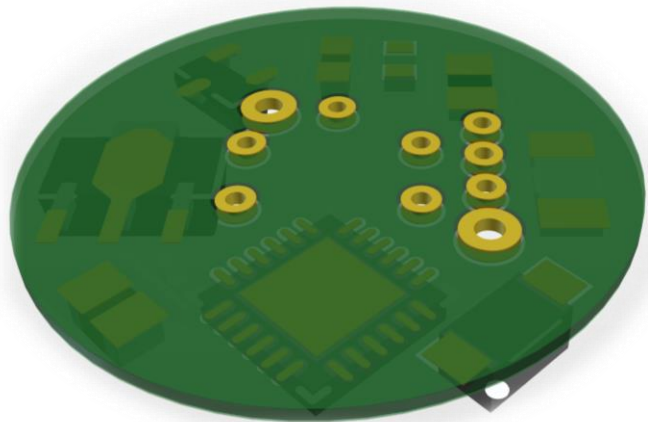
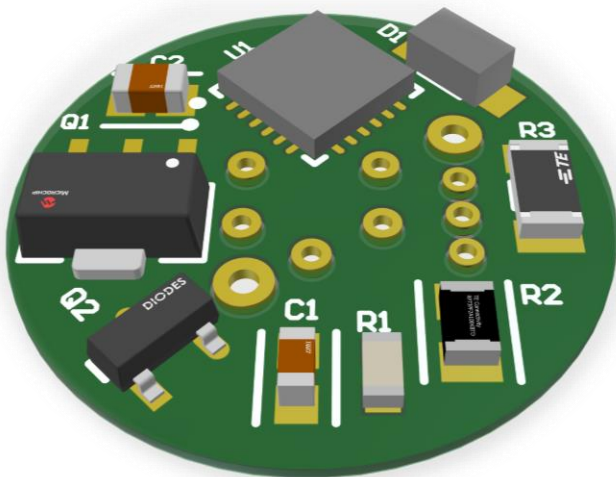
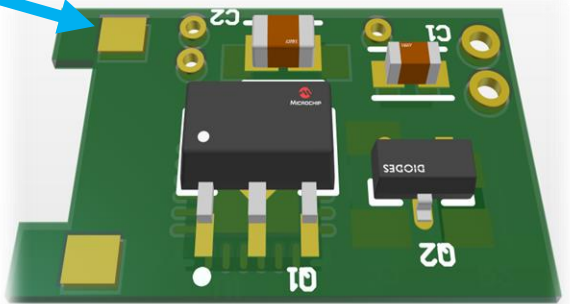
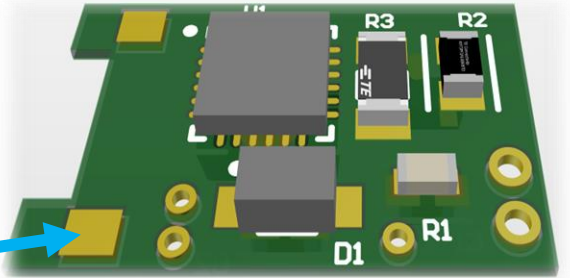
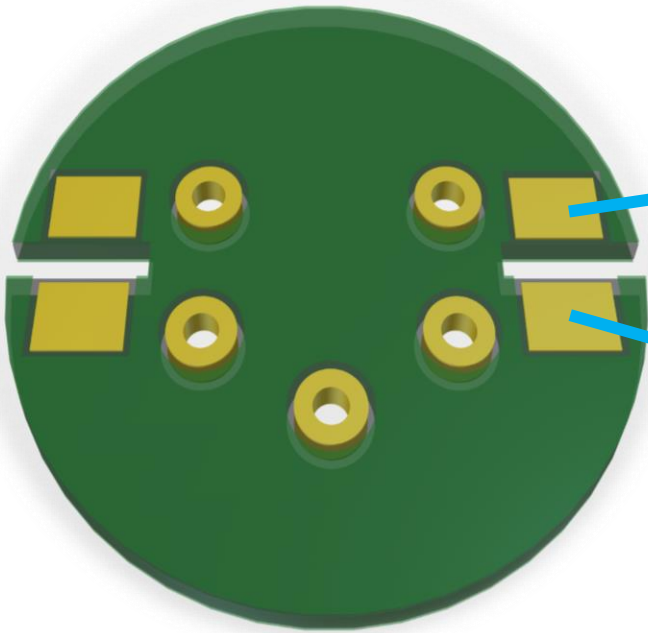

Electronic Circuit Validation:

